

Permit #



## ENTRANCE PERMIT

Return to: Administration Offices  
555 Courthouse Road,  
Cobourg, ON K9A 5J6  
(905) 972-3329 Fax (905) 372-1696

PLEASE PRINT

OWNER(S) \_\_\_\_\_ TELEPHONE \_\_\_\_\_  
Name Include Area Code  
CIVIC ADDRESS \_\_\_\_\_  
Number/Street Town /City Postal Code

I hereby make application to establish a field/residential/commercial entrance to Lot \_\_\_\_\_ Conc.  
township of \_\_\_\_\_ on the \_\_\_\_\_ side of County Road Number \_\_\_\_\_.

**Is a Setback Permit required:** Yes  No

**TO BE SUBMITTED WITH THIS APPLICATION:**

1. Attach a copy of legal survey and deed.
2. Attach a sketch showing location of structure, requested entrance, and other landmarks on the property. Please show measurements.
3. Stake centre of culvert location.
4. Could entrance be made via other road? Yes  No
5. A **deposit and fee** as set in Fee Schedule paid by certified cheque made payable to **Treasurer, Northumberland County**. This deposit may be used by the County to correct any damage to the County road resulting from construction activity by the applicant and/or his agents. The deposit is to be returned at completion of the project only when the entrance is built to an acceptable County Standard.

I/we understand that the entrance must be installed in accordance with the attached general provisions and all site specific comments by the County Inspector. This permit expires six months from date of approval if entrance is not installed.

\_\_\_\_\_  
Date of Application

\_\_\_\_\_  
Signature of Applicant

**FEE SCHEDULE**

<u>CONDITION</u>	<u>FEE</u>	<u>DEPOSIT</u>	<u>TOTAL</u>
Entrance Permit Residential	\$250	\$750	\$1,000
Entrance Permit Commercial	\$500	\$750	\$1,250
Entrance/Setback Permit Residential	\$300	\$750	\$1,050
Entrance/Setback Permit Commercial	\$600	\$750	\$1,350

**GENERAL PROVISIONS FOR ENTRANCE INSTALLATION**

The applicant agrees to the following conditions:

1. To hold the County or its agents harmless from all damages and suits arising from the said excavation or work connected with same.
2. That all work from initial opening until final closing will be completed between the hours of 9:00 a.m. Local Time Monday and 4:00 Local Time Friday (Holidays excepted) and that no work will be held over the weekend or holidays.
3. That one half of the traveled portion of the road must be kept open at all times to allow passage off emergency vehicles, etc.
4. To erect and maintain proper barricades and to light same when necessary to protect the traveling public.
5. To abide by all regulations and by-laws i.e. Occupational Health and Safety Act.
6. To install the residential entrance lines, grade and materials in accordance to the latest County Standards and the modified Ontario Provincial Standard Drawings #OPSD-301.01, 301.02, 301.03, 351.0 . Commercial entrances will be installed to a commercial standard as set by the County.
7. The most important factor with respect to any entrance is the safety of those using the County Road and the private driveway. A provision should be made so that vehicles enter and leave the County Road in a forward manner. A turnabout area off the road right-of-way is recommended.

If the entrance is not installed in accordance to the County standard, the Road Authority may withhold the Application Deposit until all concerns are rectified.

**Site Specific Comments**

**INSPECTOR'S SIGNATURE** \_\_\_\_\_ **Date** \_\_\_\_\_

<b>APPROVAL</b>	
DATE _____	_____
County Official	

**APPLICANT:** \_\_\_\_\_

**PERMIT NUMBER:** \_\_\_\_\_

**FOR OFFICE USE ONLY**

**Is this road under recent construction?** Yes  No  If "yes" when?

**Road allowance width** \_\_\_\_\_ metres

**Will entrance be:** On a hill? Yes  No  In a Valley? Yes  No   
 On a Curve? Yes  No

**This is approved as a:** Field Entrance  Residential Entrance   
 Commercial Entrance

**Could entrance interfere with future road widening an/or reconstruction?**  
 Yes  No  If "Yes" describe \_\_\_\_\_  
 \_\_\_\_\_

**Entrance to be privately installed?** Yes  No

**Detailed Site Plan Required** Yes  No   
 (Include Site grades, spot elevations, swales, cross-sections etc as required)

**COMMENTS:**

COSTS (Equipment rates include operator)

Equipment	Unit	Rate	Total
Truck	Hour	\$71.37	\$
Dozer 1	Hour	\$70.00	\$
Backhoes 1&2	Hour	\$70.00	\$
Chipper	Hour	\$20.30	\$
C.I.P	mm	\$	\$
Coupler	Each	\$	\$
Granular "A"	Tonne	\$6.20	\$
Granular "B"	Tonne	\$3.75	\$
Backfill	Cubic metre	\$3.00	\$
Labour	Hour	\$32.03	\$
Design Cost	Lump Sum		\$
Entrance Permit Fee:			
	- Residential	\$250.00	
	- Commercial	\$500.00	
Entrance / Setback Fee:			
	- Residential	\$300.00	
	- Commercial	\$600.00	
	<b>TOTAL:</b>	\$ _____	

INSTALLMENT PAYMENT SCHEDULE

<u>PAYMENT #</u>	<u>DATE</u>
<b>TOTAL</b>	

I hereby agree to pay the total above sum as specified in the above schedule.

\_\_\_\_\_  
**Signature of Applicant**

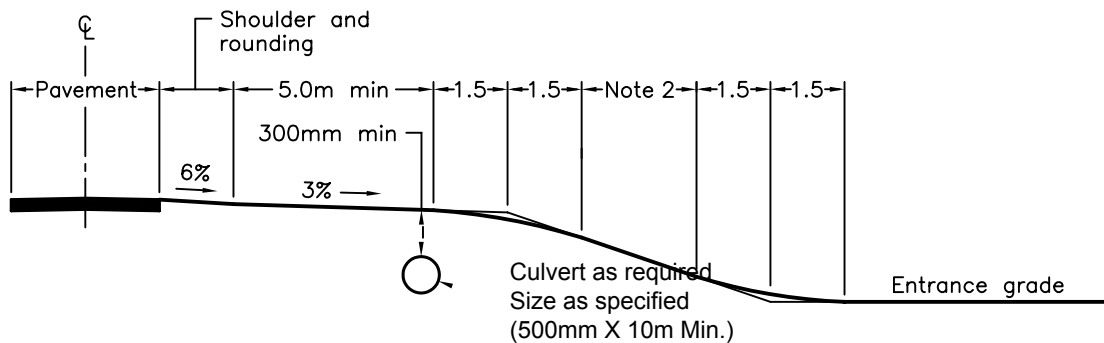
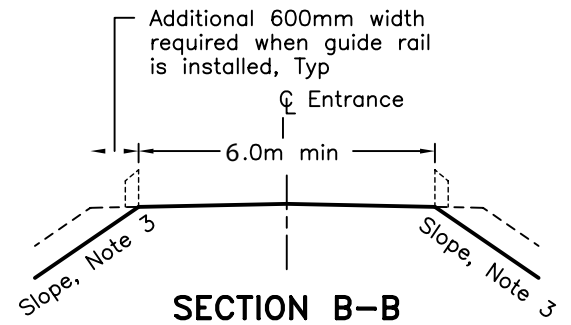
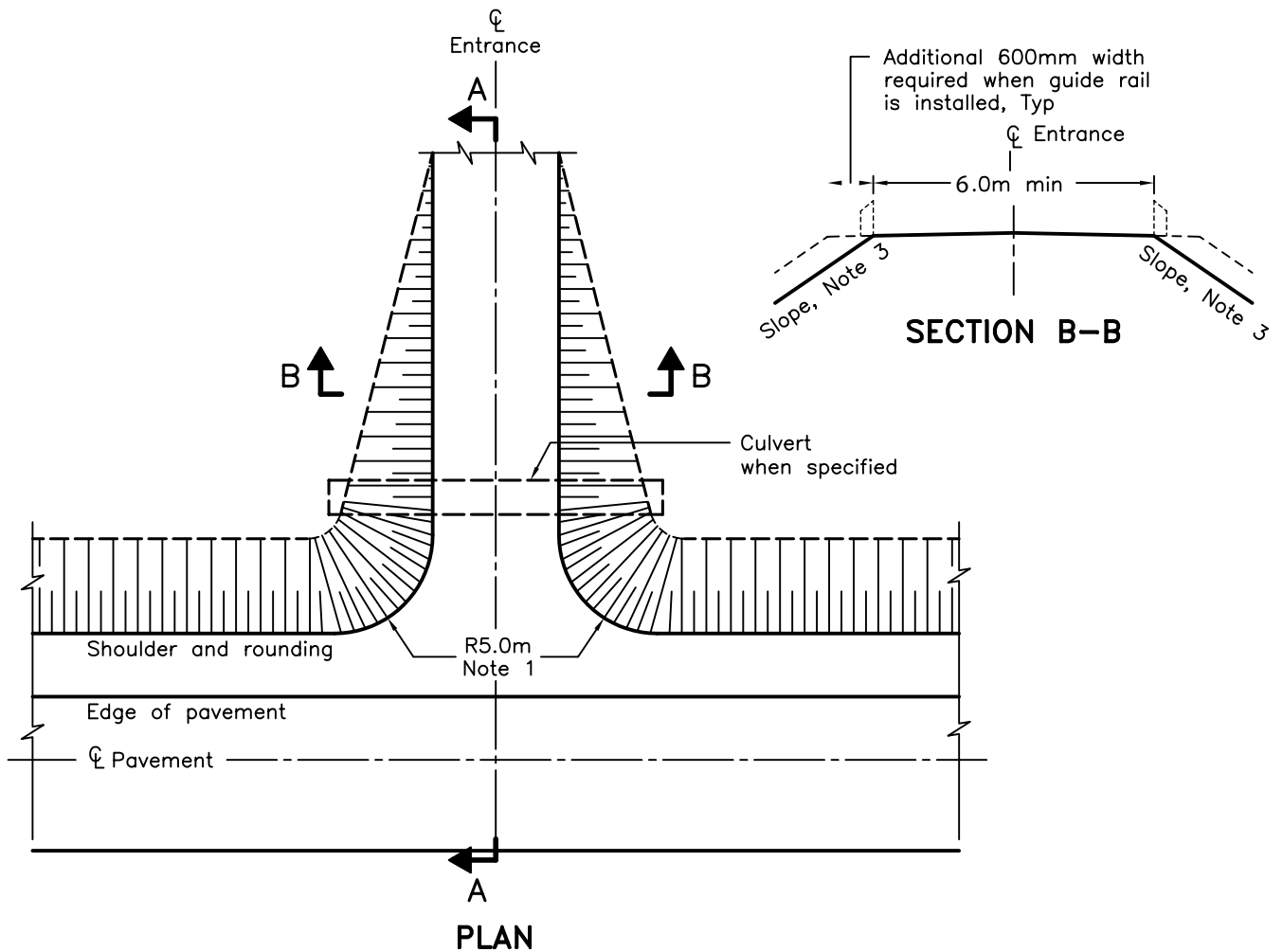

**NOTES:**

- 1 Radius shall be 8.0m when entrance is used for farm equipment.
- 2 Maximum gradient: 6% for residential entrances and 10% for farm and field entrances.
- 3 Slope shall be 2H:1V or flatter c/w 100 mm topsoil & seed (sod when specified).
- 4 All dimensions are in metres unless otherwise shown.
- 5 Minimum Materials to be: 450 Granular 'B'  
150 Granular 'A'  
50 mm Hot Mix Asphalt HL 3 (optional - as directed by the County)

ONTARIO PROVINCIAL STANDARD DRAWING

June 2010

Rev 1

**RURAL ENTRANCES  
TO ROADS ON FILL**



**OPSD- 301.010 MOD.**

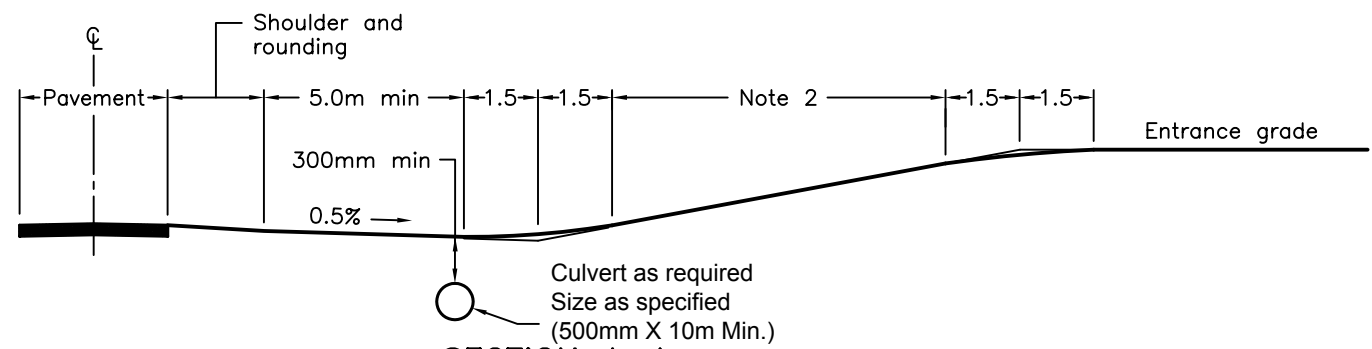
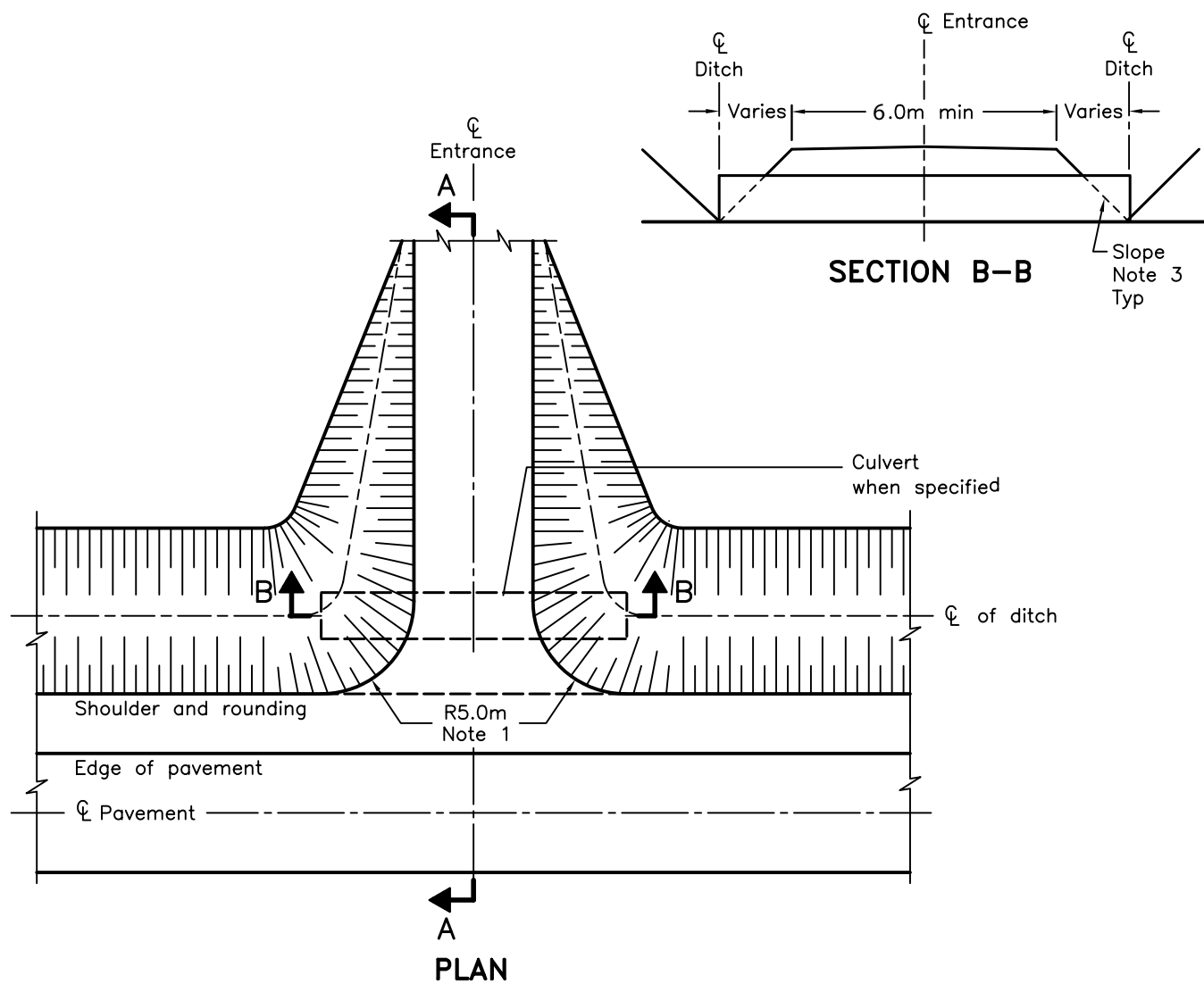

**NOTES:**

- 1 Radius shall be 8.0m when entrance is used for farm equipment.
- 2 Maximum gradient: 6% for residential entrances and 10% for farm and field entrances.
- 3 Slope shall be 2H:1V or flatter c/w 100 mm topsoil & seed (sod when specified).
- 4 All dimensions are in metres unless otherwise shown.
- 5 Minimum Materials to be:
  - 450 Granular 'B'
  - 150 Granular 'A'
  - 50 mm Hot Mix Asphalt HL 3 (optional - as directed by the Cour

ONTARIO PROVINCIAL STANDARD DRAWING

June 2010

Rev 1

**RURAL ENTRANCES  
TO ROADS IN EARTH CUT  
WITH CULVERT INSTALLATION**

**OPSD-301.020 MOD.**



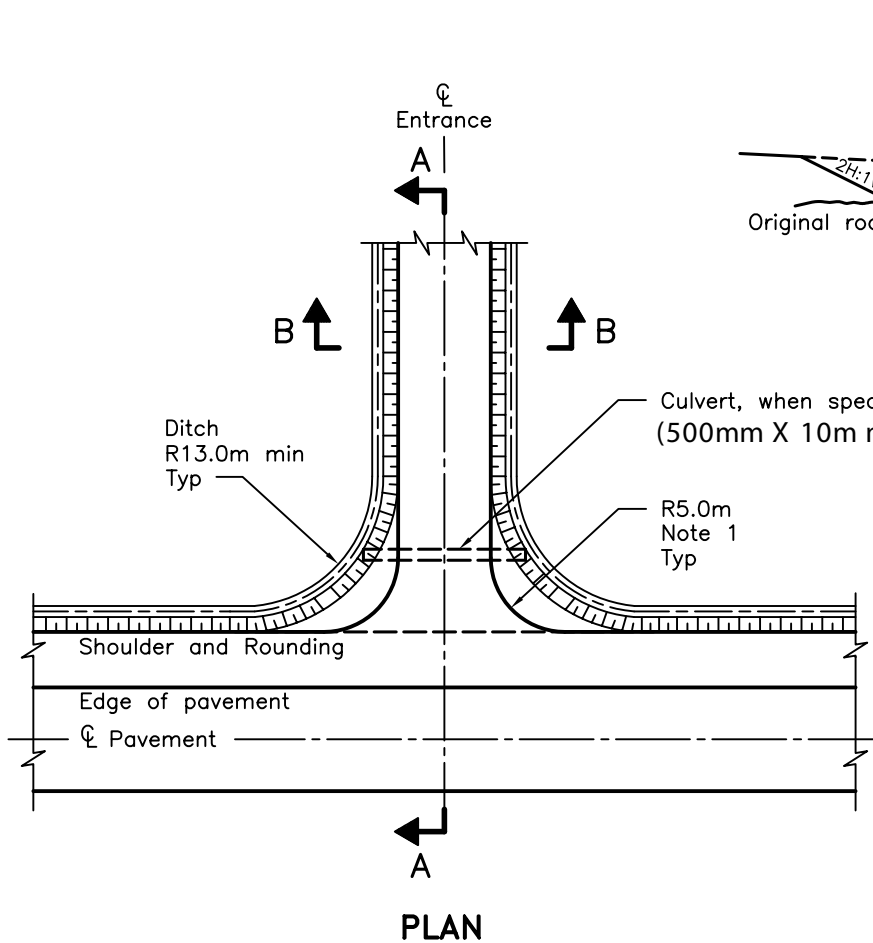

PLAN

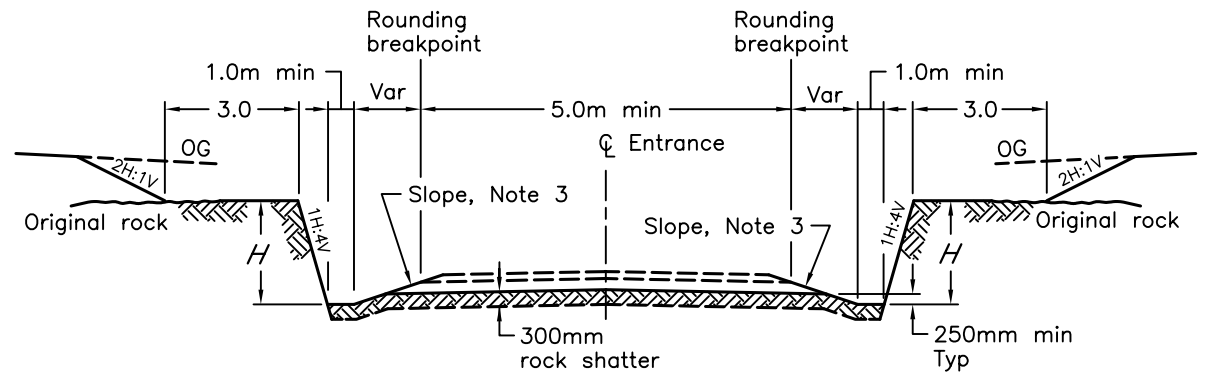

SECTION B-B

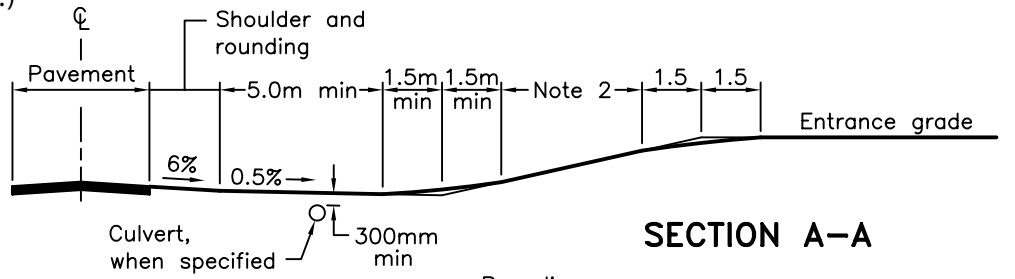

SECTION A-A

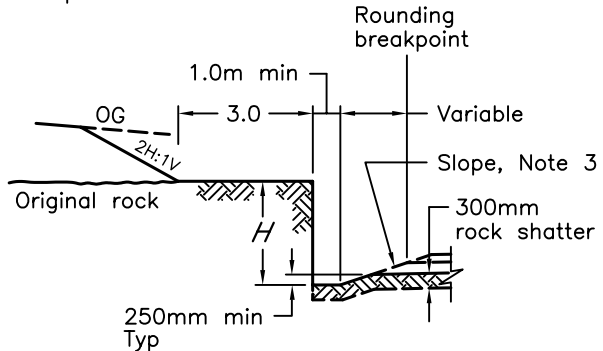

ALTERNATIVE DETAIL  
WHEN SPECIFIED

NOTES:

- 1 Radius shall be 8.0m when entrance is used for farm equipment.
- 2 Maximum gradient: 6% for residential entrances, and 10% for farm and field entrances.
- 3 Slope shall be 2 H:1V or flatter c/w 100 mm topsoil & seed (sod when specified).
- 4 All dimensions are in metres unless otherwise shown.
- 5 Minimum materials:

- 450 Granular 'B'
- 150 Granular 'A'
- 50 mm Hot Mix Asphalt HL3 (optional)

LEGEND:

H - Height of rock face

ONTARIO PROVINCIAL STANDARD DRAWING		Jan 2008	Rev 1	
<b>RURAL ENTRANCE</b>				
ROCK CUT				
<b>OPSD - 301.030</b>				

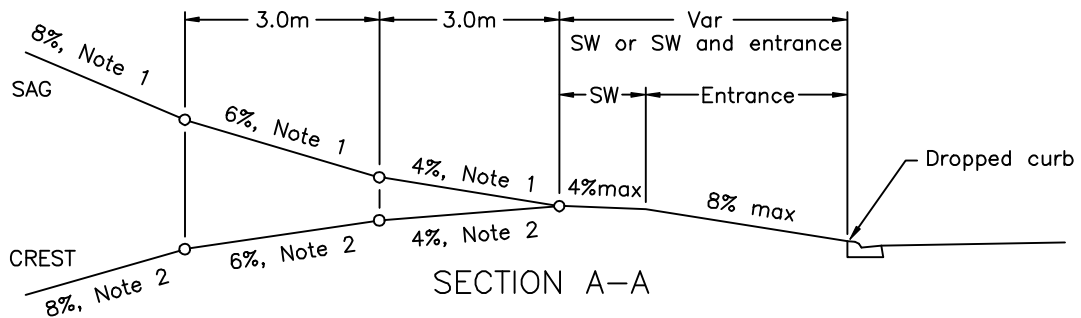
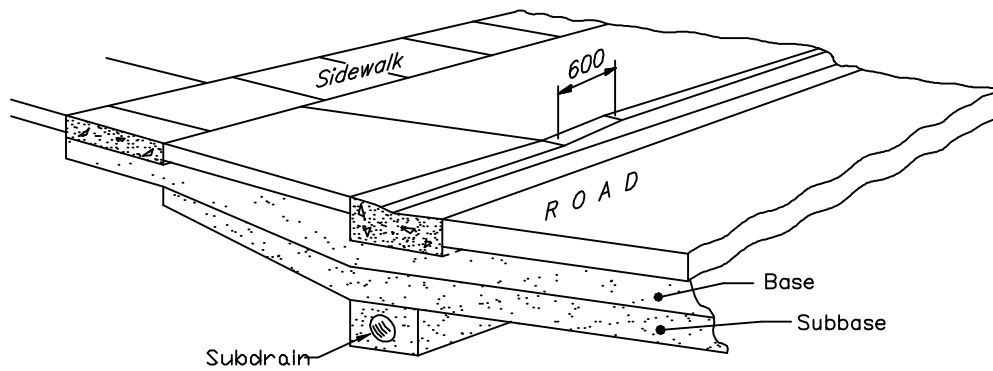
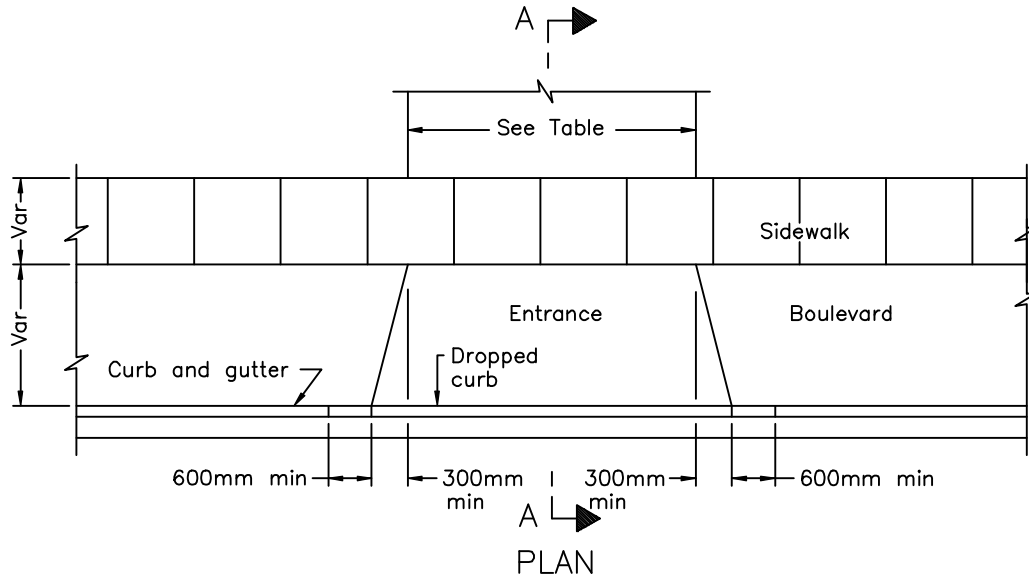

NOTES:

- 1 Maximum upgrade shall be 10%.
- 2 Maximum downgrade shall be 8%.
- 3 All dimensions are in millimetres unless otherwise shown.
- 4 Minimum materials: 450 Granular 'B'  
150 Granular 'A'  
50 mm Hot Mix Asphalt HL3 (fully paved within road allowance)  
100 mm topsoil & sod in boulevard

DRIVEWAY DIMENSIONS				
LAND USE	WIDTH m			
	Single		Double	
	min	max	min	max
Residential	3.0	4.3	6.0	7.3

ONTARIO PROVINCIAL STANDARD DRAWING

Jan 2008

Rev

URBAN RESIDENTIAL  
ENTRANCE



OPSD-351.010 Mod.